

COUNTERTOP PRODUCT LINE

# A SOLUTION FOR EVERY FABRICATOR

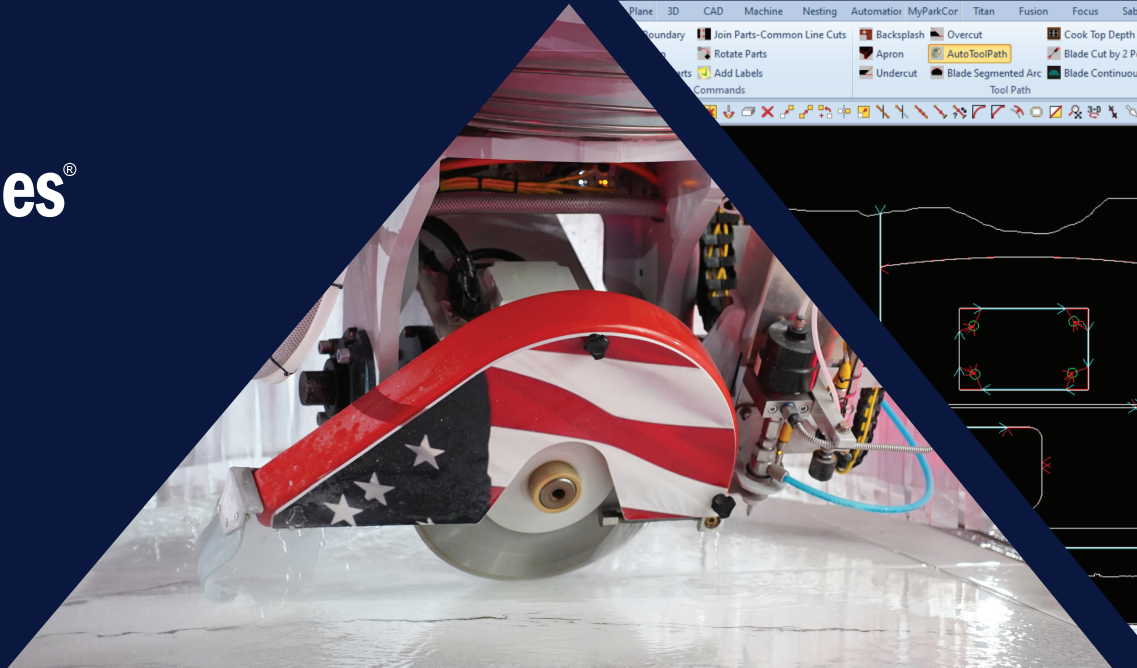

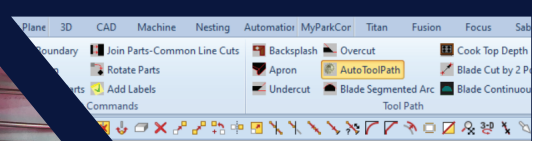

**98.67%**  
MACHINE MET  
EXPECTATIONS

**100%**  
RECOMMEND PARK  
MACHINES

**96.67%**  
IMPACTED  
PROFITABILITY

\*Percentages gathered from survey of over 1,000 current Park customers.

# ▶ North America's Largest Manufacturer of Stone Machinery



## INNOVATION & DESIGN

70+ years of experience, extensive R&D testing and a team of in-house engineers result in innovative, highly productive solutions.



## PROUD USA MANUFACTURER

Our machines are precision built in our state-of-the-art, vertically integrated manufacturing facility, located in Minnesota, USA.



## MACHINE & SOFTWARE TRAINING

Park makes it easy to master your machine with small class sizes, dedicated trainers, and flexible learning options.



## EXPERT INSTALLATION & FIELD SERVICE

Our team of Certified Field Techs provide complete installation of your new machine and set you up for long-term success. With quick dispatch times and preventative services like machine health checks, they help keep your equipment running at its best.



## LEGENDARY SERVICE

24/7 phone support, next-day parts and the industry's largest (and most helpful) service team make our machinery the lowest risk, highest peace of mind solutions.



## YOUR TRUSTED PARTNER

With nearly 20,000 machines built and over 5,000 customers, Park Industries goal is simple: set our customers up for long-term success.

# CUT PORCELAIN CONFIDENTLY WITH PARK INDUSTRIES

Our CNC sawing solutions are optimized for cutting porcelain and other ultracompact materials with precision and ease. With features designed specifically for porcelain and helpful tips, we can help you cut this trending material with confidence.



**SCAN TO ACCESS  
HANDS-ON PORCELAIN  
CUTTING GUIDES**



# ▶ **SAWING** **SOLUTIONS**

JAVELIN™ | SABERJET™ XP | VOYAGER™ XP | YUKON® II | CROSSCUT™ XP

# JAVELIN™

27HP MOTOR  
WITH VFD

BLADE & WATERJET  
MITERING

MAXIMUM TABLE  
COVERAGE & LARGEST  
MITER ENVELOPE



## KEY SPECS

- Arbor Motor: 27hp
- Mitering: 0-47° Blade, 0-58° Waterjet
- VFD RPM Range: 0-4,500
- Max Slab Size: 144" x 88"
- Auto Lubrication: Yes
- Table Options: Standard or Slab Loader



**SINGLE OR DOUBLE TABLE  
MODELS AVAILABLE**

## THE ONLY SAWJET THAT HITS EVERY TARGET

The JAVELIN CNC Sawjet's high production speeds, precise mitering accuracy, maximum table coverage, and operational ease have made it North America's sawjet of choice.

**ACCUCUT™ SYSTEM FOR UNMATCHED PRECISION**

**DYNAMAX® WATERJET TECHNOLOGY**

**THREE-SIDED TABLE ACCESS**

**SMALLEST DOUBLE TABLE FOOTPRINT**

**EZ CAL WITH AUTOMATIC TOOL MEASUREMENT**

**PERIMETER FENCING AVAILABLE**

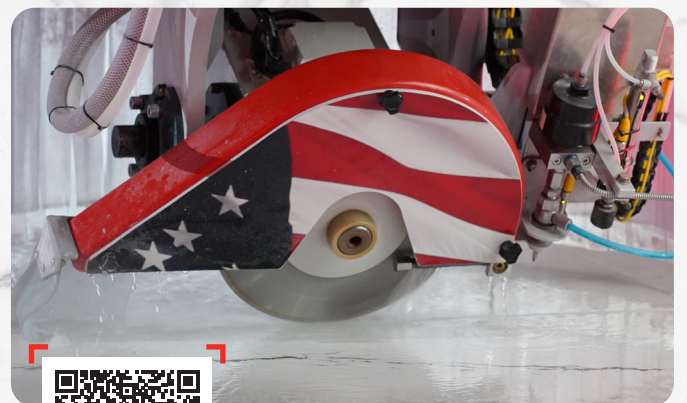

**SCAN TO LEARN MORE ABOUT THIS MACHINE**



# SABER *jet*™ XP

BLADE & WATERJET  
MITERING

STANDARD, BALLAST,  
OR SLAB LOADER TANK  
OPTIONS

DYNAMAX® WATERJET  
TECHNOLOGY

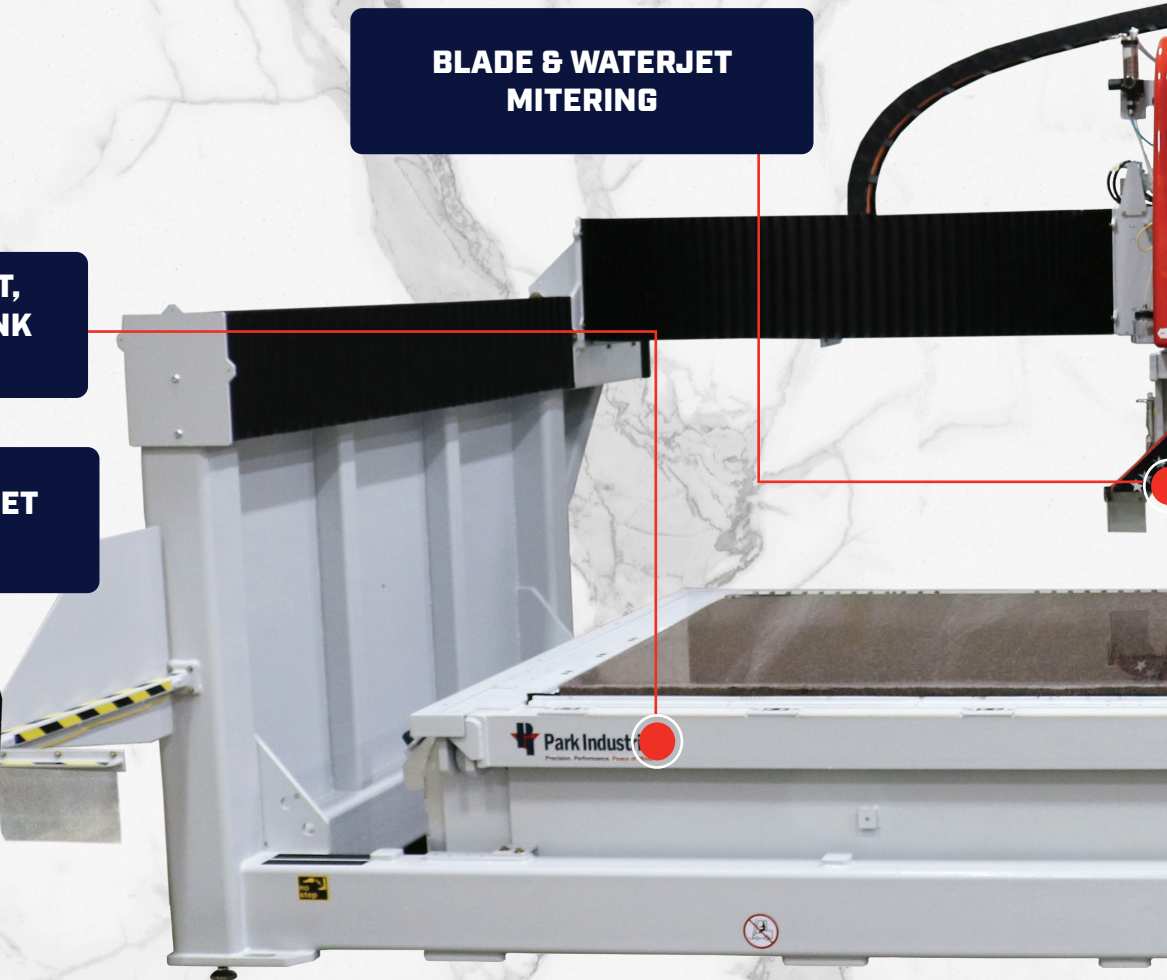

## KEY SPECS

- Arbor Motor: 27hp
- Mitering: 0-47° Blade, 0-58° Waterjet
- VFD RPM Range: 1,200-2,500
- Max Slab Size: 144" x 84"
- Auto Lubrication: Optional
- Table Options: Standard, Slab Loader, or Ballast

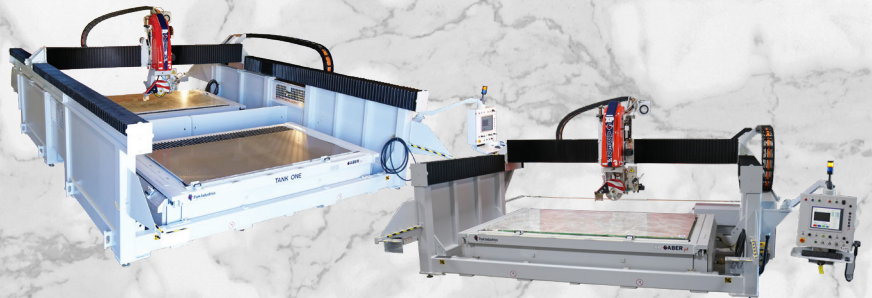

SINGLE OR DOUBLE TABLE  
MODELS AVAILABLE

## POWER UP WITH XP

The SABERjet XP CNC Sawjet's high horsepower, mitring capabilities, flexible operation, and monoblock design provide big time production, with a more value-priced sawjet investment.

**27HP MOTOR  
WITH VFD**

**MANUAL CUTTING CAPABILITY  
WITH LASER GUIDE**

**MONOBLOCK, SINGLE  
STRUCTURE DESIGN**

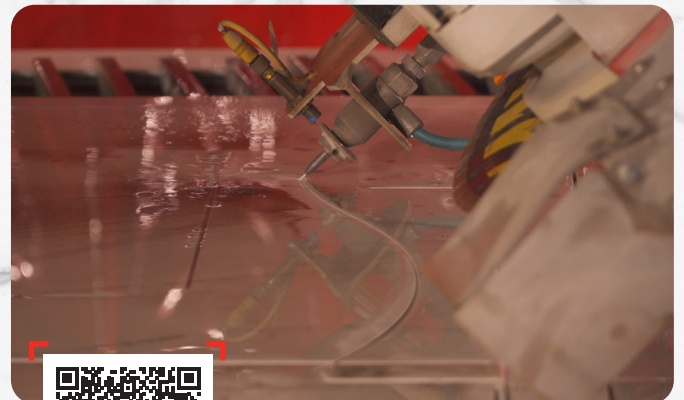

**SCAN TO LEARN MORE  
ABOUT THIS MACHINE**

# VOYAGER™ XP

**TIGHTCUT™ FOR HIGHER  
YIELD & LESS MILLING**

**INCREMENTAL ROUTER  
FOR CORING & MILLING**

**MONOBLOCK, SINGLE  
STRUCTURE DESIGN**

**MITERING, LEATHERING,  
FLUTING, & MORE  
VERSATILE CAPABILITIES**

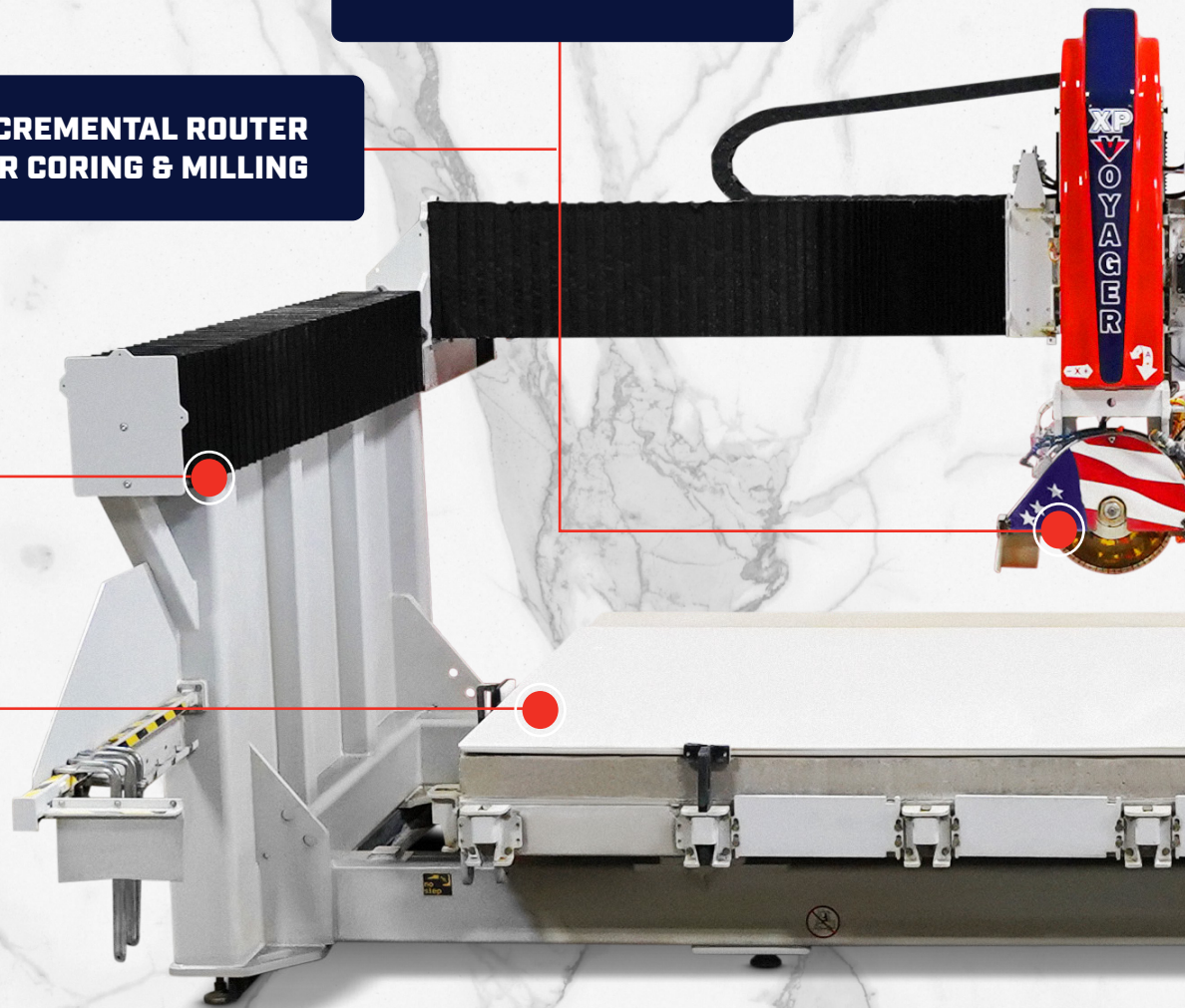

## KEY SPECS

- Arbor Motor: 27hp
- Mitering: 0-47°
- VFD RPM Range: 1,000-6,000
- Max Slab Size: 144" x 84"
- Auto Lubrication: Optional
- Table: Hydraulic Tilt

**WITH TIGHTCUT**

**MINIMAL ROUTING**

NEARLY HALF THE MILLING TIME NEEDED

**WITHOUT TIGHTCUT**

**INCREASED ROUTING**

NEARLY DOUBLE THE MILLING TIME NEEDED

# 5-AXIS CNC SAW

## IT'S TIME FOR A NEW VOYAGE

Voyage into digital fabrication with the VOYAGER XP CNC Saw, a versatile 5-axis machine with 27hp sawing, incremental router capabilities, TightCut™ plunging, and more.

**27HP MOTOR WITH VFD**

**MANUAL CUTTING CAPABILITY WITH LASER GUIDE**

**HYDRAULIC TILT TABLE**



**SCAN TO LEARN MORE ABOUT THIS MACHINE**

# YUKON® II

## BRIDGE SAW

### NORTH AMERICA'S MOST TRUSTED BRIDGE SAW

Simple, reliable, accurate – trust your sawing needs to the YUKON® II Bridge Saw as thousands of fabricators do.

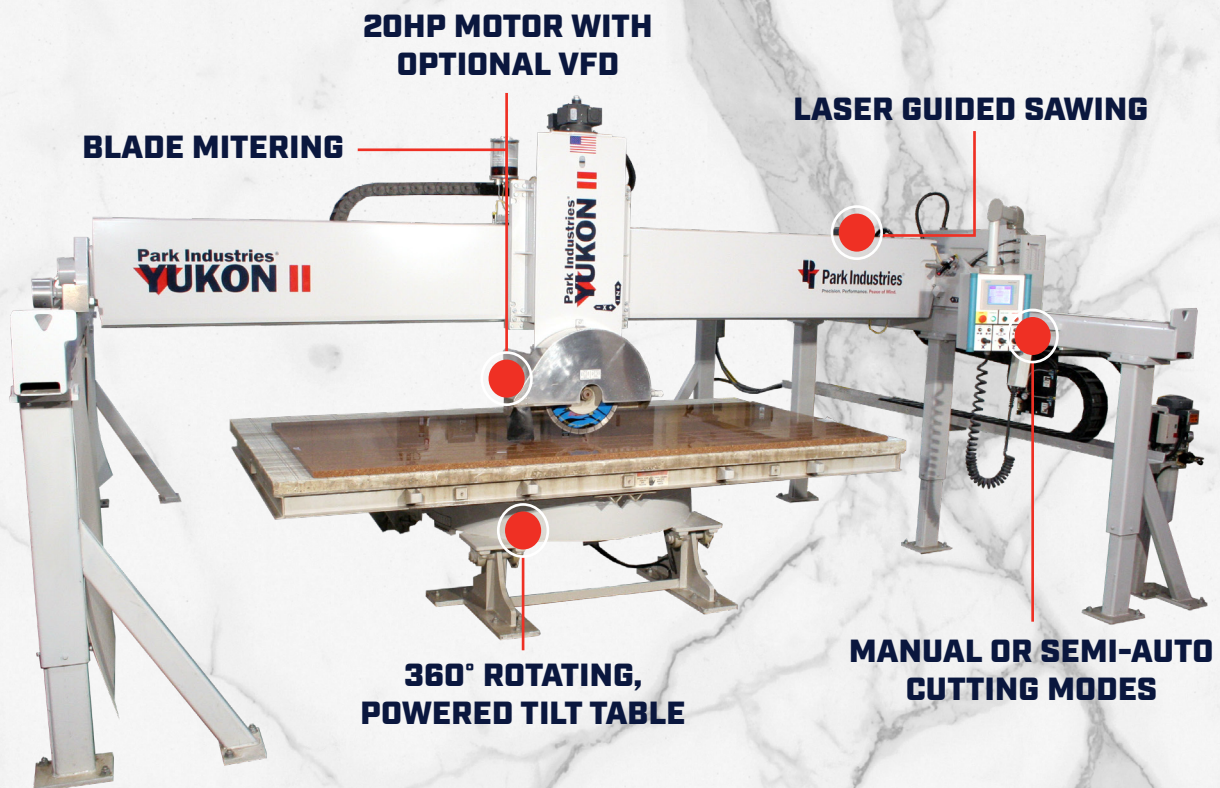

#### KEY SPECS

- Arbor Motor: 20hp
- Mitering: 0-47°
- VFD RPM Range: 900-2,650
- Max Slab Size: 144" x 84"



**SCAN TO LEARN MORE ABOUT THIS MACHINE**

# CrossCut™ XP

## MITER SAW

### MITER PERFECTION WITH EVERY CUT

Designed for one thing, and one thing only, the CrossCut™ XP Miter Saw delivers accurate miters with every cut. Cut flawless miters up to 55 inches per minute!

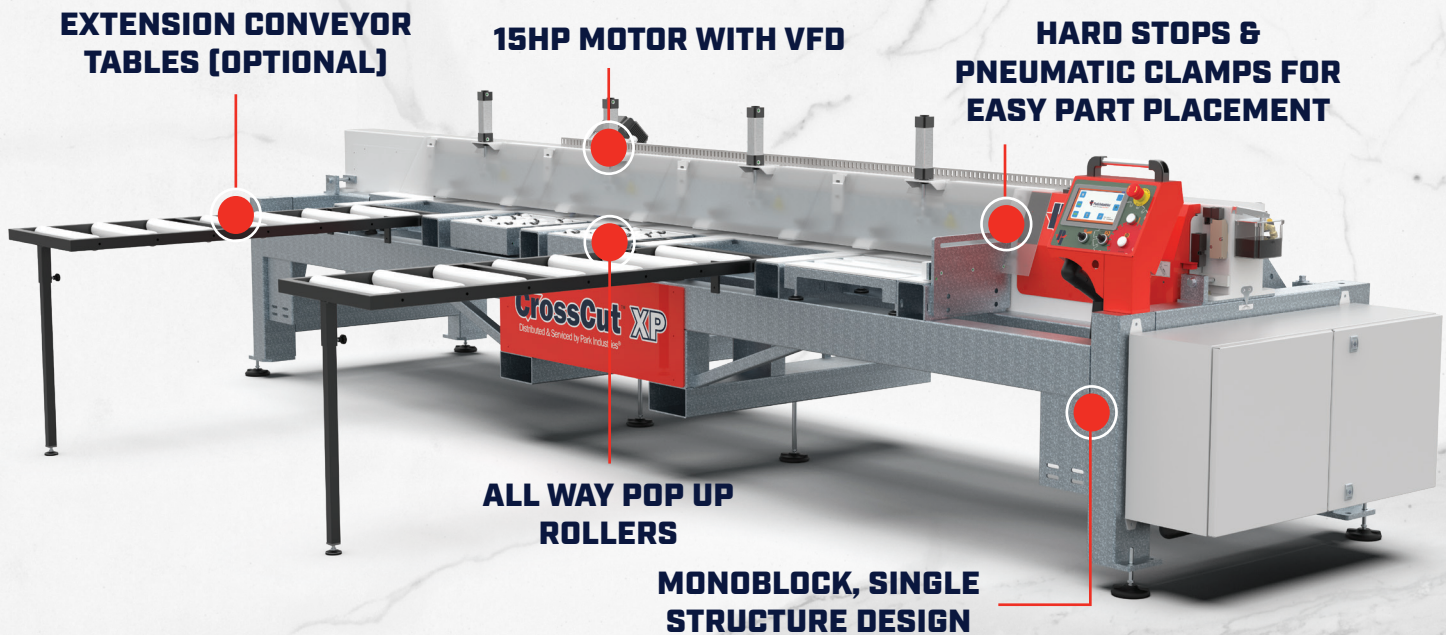

#### KEY SPECS

- Arbor Motor: 15hp
- Mitering: 45° (+/- 2°)
- VFD RPM Range: 0-3,600
- Max Part Length: 132.5"

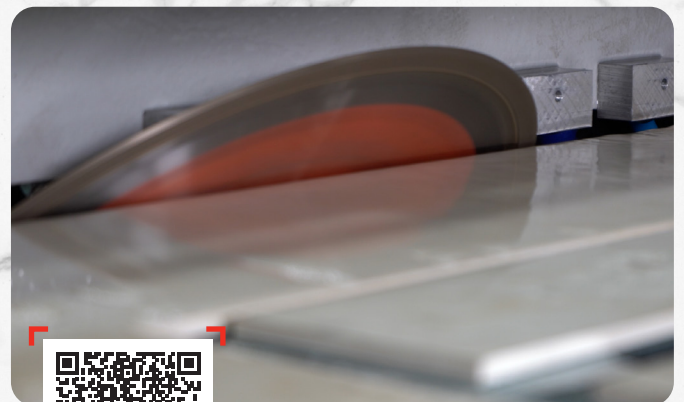

**SCAN TO LEARN MORE ABOUT THIS MACHINE**

# FLY TO **PARK**



## GET A MACHINE DEMO ON US

Fly to Park Industries® in Minnesota – on us – to learn how to reduce your costs and supercharge your production. Get up close and personal with our machines, team, and entire slab to fab process. With your travel covered, you can confidently ensure your next investment is the right one.



- ✓ **LIVE MACHINE DEMOS**
- ✓ **TOUR OUR FACILITY & MEET OUR TEAM**
- ✓ **LEARN HOW TO REDUCE COSTS & INCREASE PRODUCTION**



**SCHEDULE YOUR DEMO  
AT PARK (ON US)**

[parkindustries.com/flytopark](http://parkindustries.com/flytopark)



▶ **PROFILING  
& POLISHING  
SOLUTIONS**

TITAN® | SPARTAN™ | FASTBACK® II | VELOCITY®

# TITAN<sup>®</sup>

LASER PROJECTOR FOR  
POD/PART PLACEMENT

MAINTENANCE FREE  
ARMORDECK WORK SURFACE

INDUSTRY-LEADING  
WORK AREA

## KEY SPECS

- Spindle Motor: 21hp with 5 Year Warranty
- Tool Pockets: Up to 68
- RPM Range: 100-8,000
- Work Area: Up to 8' x 16'
- Traverse Speeds: Up to 2600 IPM (X/Y)
- Auto Lubrication: Yes

4700 OR 4800  
MODELS AVAILABLE

# ONLY A TITAN SHAPES GREATNESS

With the TITAN 4000 Series, unmatched efficiency, uptime, and production come together as the pinnacle of CNC router productivity. Finish sinks, large islands, seams, L pieces, and any other part or profile with ease.

**21HP QUANTUM™ BELT DRIVE SPINDLE**

**INDUSTRY-LEADING 68 TOOL POCKETS WITH QUICK-SCAN TECHNOLOGY**

**PRECISION HELICAL RACK AND PINION SYSTEM**



**SCAN TO LEARN MORE ABOUT THIS MACHINE**

# SPARTAN™

PRECISION HELICAL RACK  
AND PINION SYSTEM

LARGE OPENING FOR  
EASY FRONT LOADING  
WITH CRANE

ALL WAY ROLLERS &  
OPTIONAL CONVEYORS FOR  
EASY PART HANDLING

MONOBLOCK, SINGLE  
STRUCTURE DESIGN

## KEY SPECS

- Spindle Motor: 21hp
- Tool Pockets: 19 (2 Sets + 5 Utility)
- RPM Range: 100-8,000
- Options: Alphacam, Roller Conveyors, Front Support Stand

# SINK & SEAM CNC ROUTER

## WIN THE SINK BATTLE

Ready to dominate sink work? Deploy SPARTAN™ – your shop's ultimate sink and seam solution. Our compact CNC router cuts and polishes high-quality sink openings in minutes. SPARTAN's Load N' Go system and built-in sink template library make your workflow effortless - no programming required. Conquer sinks and seams with speed, safety, and simplicity with SPARTAN.

**21HP QUANTUM™ BELT DRIVE SPINDLE**

**LARGE TOUCHSCREEN HMI WITH MULTILINGUAL CONTROLS**

**SINK TEMPLATE LIBRARY, PARAMETRIC SINK CREATION & BUILT IN SEAM SETUP**

**CAPABLE OF RUNNING LARGE, MITERED, LAMINATED & MORE PARTS**

**LOAD N' GO SYSTEM WITH BUILT IN VACUUM CUPS & POP-UP TABLE**

*(Patent Pending)*



**SCAN TO LEARN MORE ABOUT THIS MACHINE**

# FASTBACK® II

**NINE SPINDLES FOR  
EXCEPTIONAL POLISH  
QUALITY ON ALL MATERIALS**

**HEAVY DUTY INFEED /  
OUTFEED CONVEYORS**



## KEY SPECS

- Edge Type: Flat with Chamfers
- Number of Spindles: 9
- Polishing Speed: 65"+ per minute
- Part Length: 16"-144"
- Part Width: Up to 96" (Standing up)



**AVAILABLE WITH OR  
WITHOUT SLABBACK™**

## **OPTIMAL, FLAT-EDGE PRODUCTION**

The FASTBACK II Flat-Edge Polisher edges, polishes and chamfers backsplash, vanities, and countertops in a single pass. Get exceptional, quality edges on all colors at a rate up to 65 IPM and pieces up to 96" tall with the SlabBACK Support System.

**SLABBACK™ SUPPORT SYSTEM (OPTIONAL)**

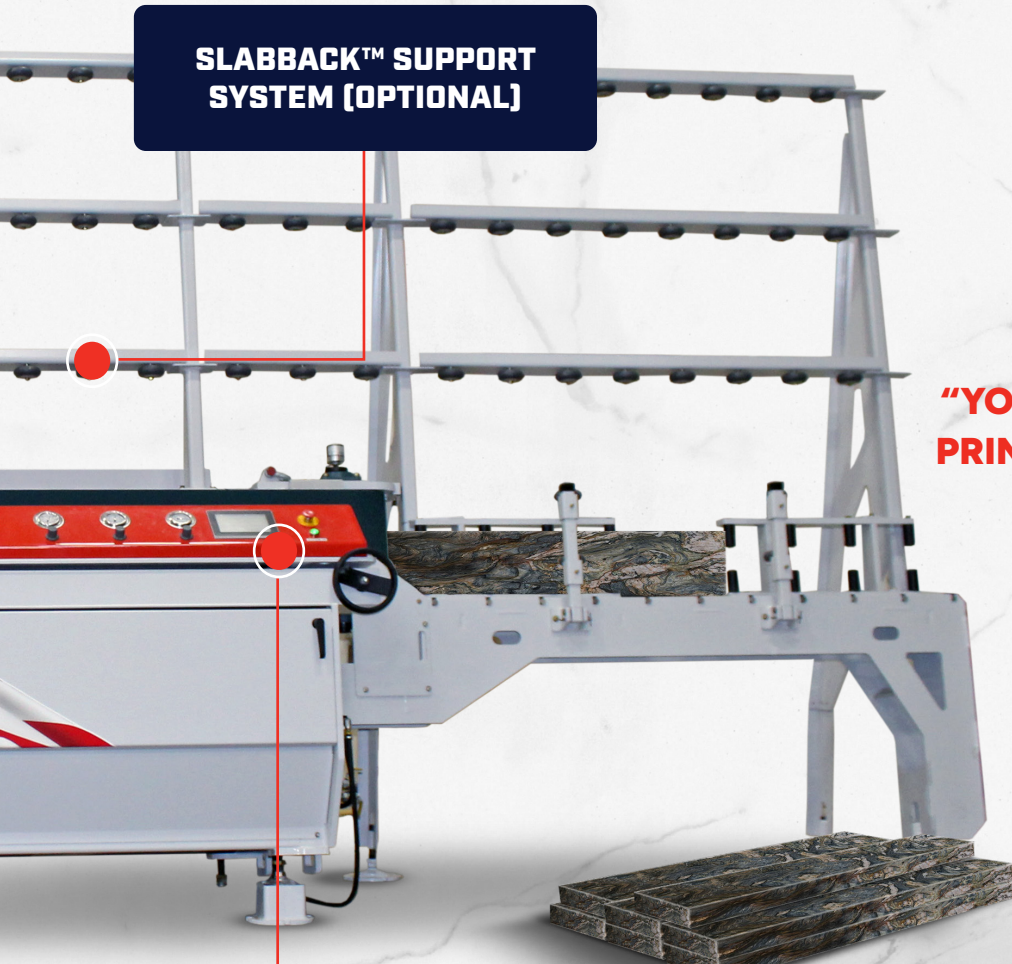

**“YOU PUT STONE IN ONE END AND IT PRINTS MONEY ON THE OTHER SIDE.”**

**SMARTEST FLAT EDGER IN INDUSTRY**

**EXCLUSIVE SPINDLE STAGGER**



**SCAN TO LEARN MORE ABOUT THIS MACHINE**

# VELOCITY<sup>®</sup>

70 REPEATABLE  
PROFILES

SINGLE PASS PROFILING  
& POLISHING

MATERIAL HANDLING  
CONVEYOR SYSTEM

## KEY SPECS

- Edge Types: 70 Repeatable Profiles (Flat, Radius, Decorative)
- Number of Spindles: 12
- Polishing Speed: 12"-24" per minute
- Part Length: 24"-144"
- Part Width: 4"-144"

# DECORATIVE EDGE POLISHER

## GET THE EDGE

The VELOCITY Edge Polisher shapes and polishes nearly any edge profile in a single pass to a glass like finish with easy material handling and operation. Game changer.



**12 SPINDLES**

**PNEUMATIC  
HOLD-DOWNS**

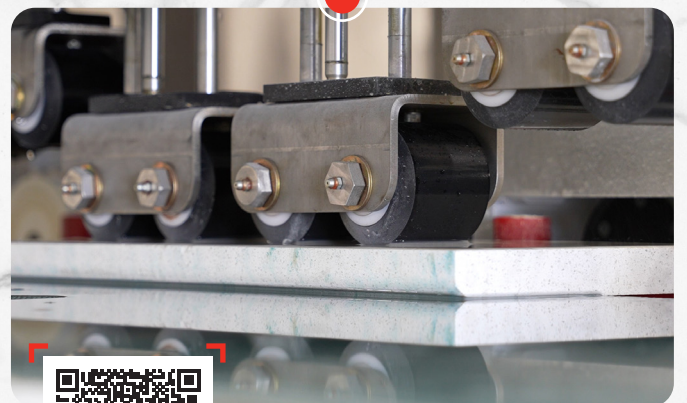

**SCAN TO LEARN MORE  
ABOUT THIS MACHINE**

# FABRICATOR SPOTLIGHTS



Adding the right machinery delivers real results. See how top fabricators are transforming their shops for increased efficiency, precision, and profitability with Park Industries.



**SCAN TO LEARN  
MORE ABOUT THEIR  
SUCCESS STORIES**

A close-up photograph of a water filtration system. Water is being filtered through a circular mesh screen, creating a series of vertical streams of water falling into a dark container below. The background is a dark blue gradient.

# ▶ WATER SYSTEMS SOLUTIONS

HYDROCLEAR® PRO SERIES

# HydroClear™

## PRO SERIES

WATER RECYCLING UP TO  
325 GPM

PIT STIR SYSTEM

ADVANCED  
TOUCHSCREEN  
CONTROLLER (OPTIONAL)

AUTOMATED 4 CHEMICAL  
DOSING SYSTEM (OPTIONAL)

### KEY SPECS *(Varies by model)*

- Sustained Flow Rate (GPM): 35-325
- Peak Flow Rate (GPM): 53-580
- Repress Pump: 3hp–Dual 15hp Motors
- Slurry Pump Motor: 1hp-5hp
- Sludge Skids: 1-4
- VFD: Optional



7 UNIQUE MODELS AVAILABLE

# THE CHOICE IS CLEAR

The HydroClear Pro Water System Series efficiently recycles and cleans your shop's water. With seven unique models available, shops of all sizes can ensure sufficient water supply, save big on their water bill, and fabricate responsibly.

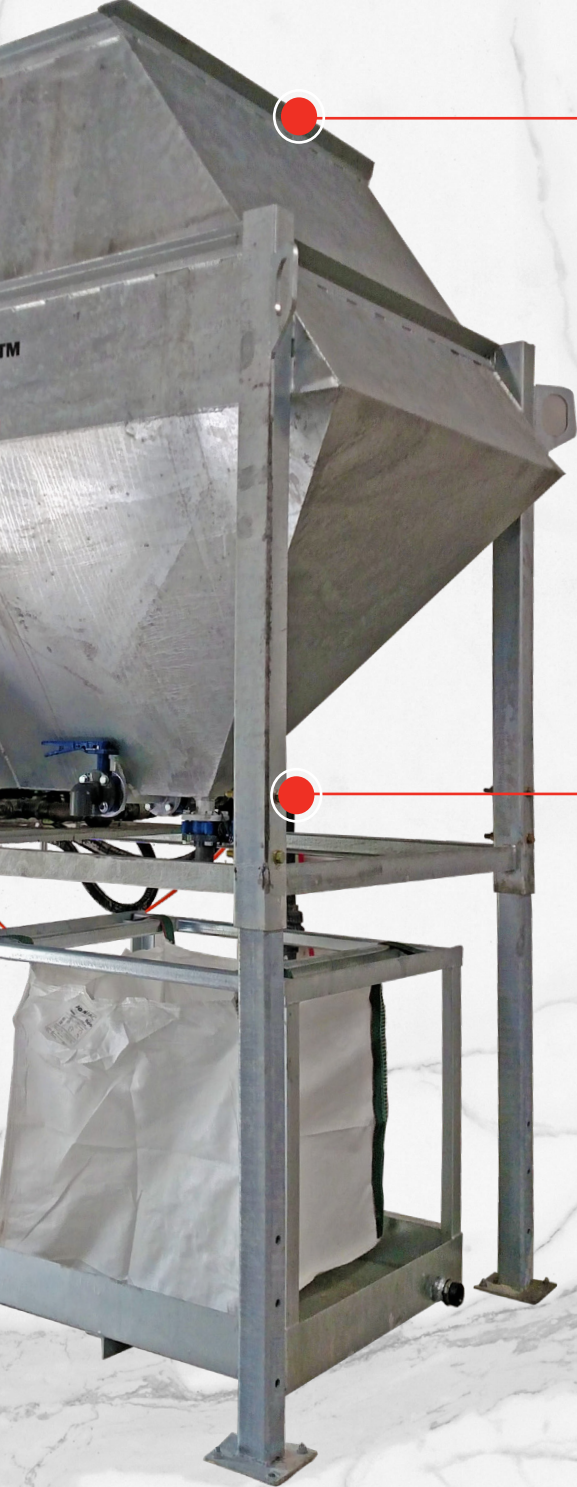

**REMOVES UP TO 95% OF SOLIDS IN RECYCLED WATER**

**AUTOMATIC PURGE VALVE**

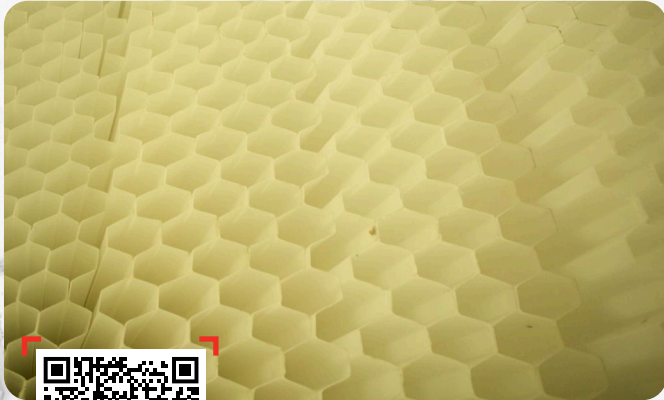

**SCAN TO LEARN MORE ABOUT THIS MACHINE**

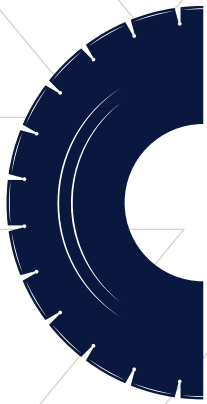

 Park Industries®

# CUT THIS POLISH THAT



Join our team of highly knowledgeable application specialists to gain fabrication insights and watch industry-leading machinery take on anything!

This series goes beyond the machines, with tips and trends just for stone fabricators helping YOU grow your skills, your knowledge, and of course, your business.



**SCAN TO WATCH  
THE LATEST  
EPISODES**



# ▶ IMAGING & SOFTWARE SOLUTIONS

# /SLAB VISION™

**ADVANCED LED  
CONTROLLED LIGHTING**

**ULTRA HIGH-RESOLUTION  
32 MEGAPIXEL IMAGING**



## **KEY SPECS**

- Camera: Single 32 MP Ultra HD
- Lighting: Advanced LED System Eliminates Environment Issues
- Max Slab Size: 156" x 87"
- Controller: 24" Touchscreen

**COMPACT FOOTPRINT**

# SLAB SCANNER

## CAPTURE EVERYTHING

SlabVision is the ultimate slab capture tool for stone fabricators, offering unparalleled precision imaging, effortless operation, and efficient slab inventory management, all in a compact design.

**INDUSTRY-LEADING SLAB  
SIZE CAPACITY  
156" X 87"**

**MOTORIZED JACK FOR  
EASY SLAB LOADING**

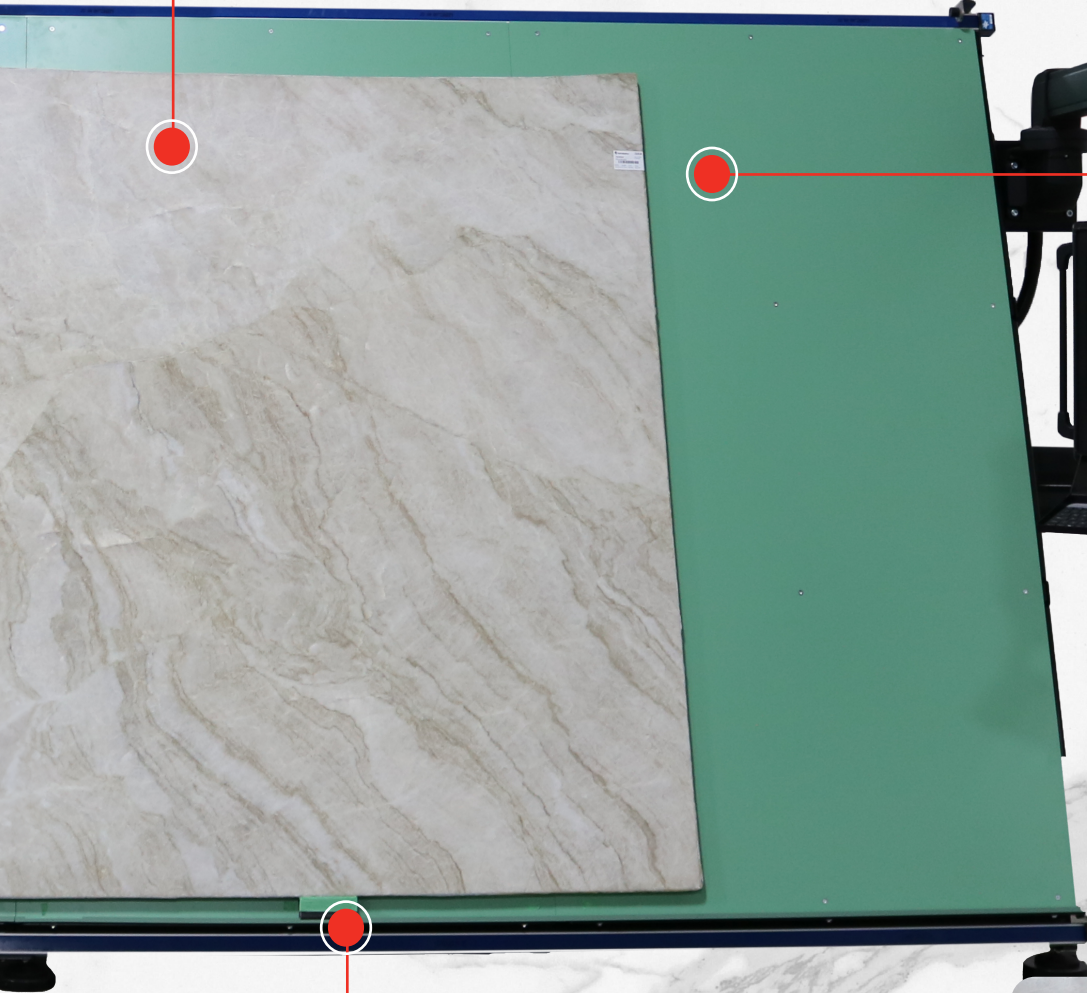

**24" MOVEABLE  
TOUCHSCREEN  
CONTROLLER**

**EASY SCANNER-TO-SAW  
SLAB LOCATING**



**SCAN TO LEARN MORE  
ABOUT THIS MACHINE**

# Pathfinder<sup>®</sup>

## DIGITAL SLAB STATION

### SIMPLE. SMART. SLAB IMAGING.

Capture precise, fully-calibrated images of your slabs in high resolution with the all-in-one Pathfinder<sup>®</sup> Digital Imaging workstation.

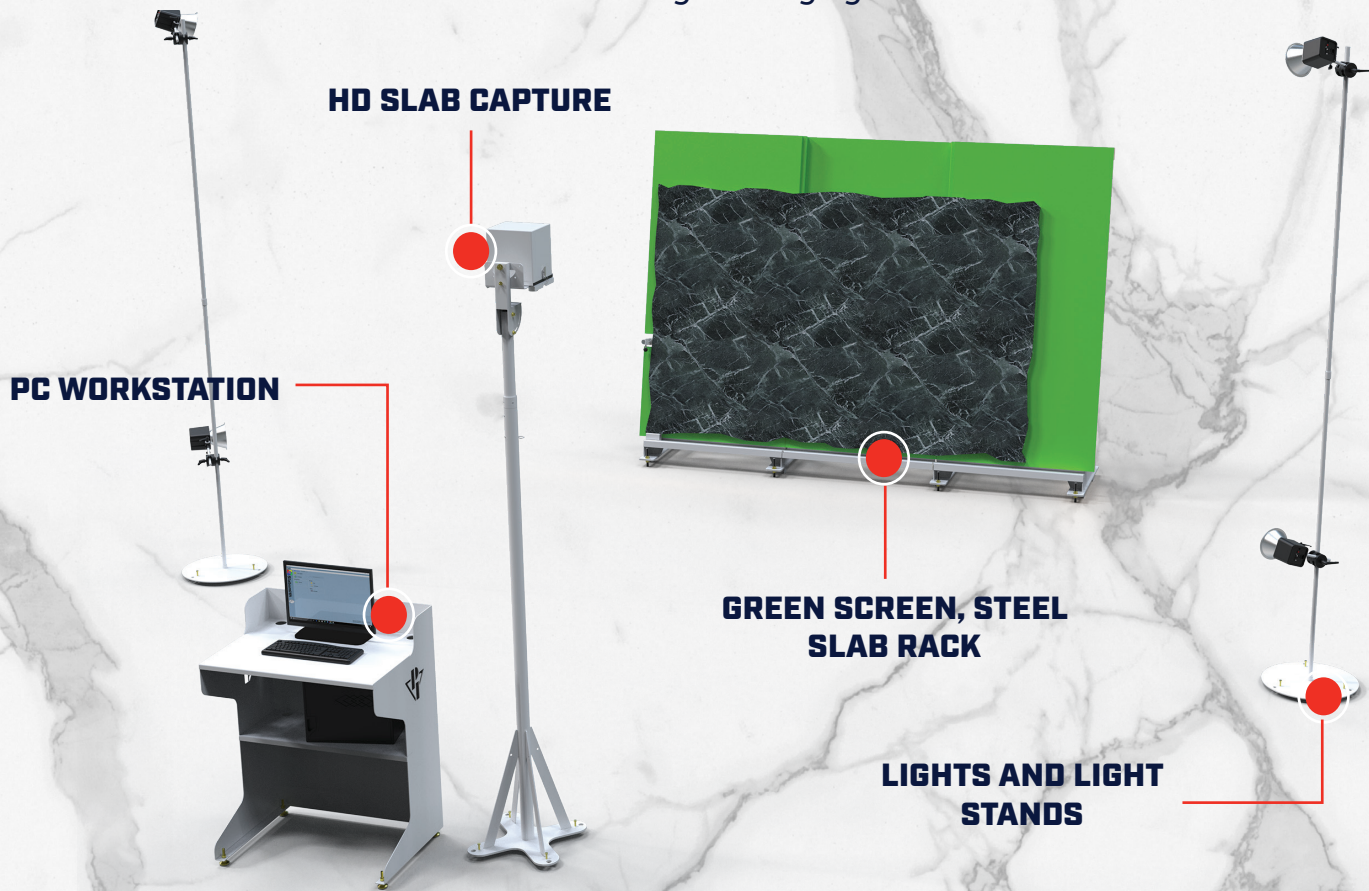

#### KEY SPECS

- Camera: HD Camera
- Lighting: Flash Lights & Light Stands
- Max Slab Size: 144" x 84"
- Controller: PC Computer



**SCAN TO LEARN MORE  
ABOUT THIS MACHINE**

# SIDE-SHOT™

## DIGITAL SLAB STATION

### THE PERFECT CNC SAW SIDEKICK

The SIDE-SHOT provides fabricators tools to capture slab images right at the machine with an extremely small footprint and lower investment than other slab imaging solutions.

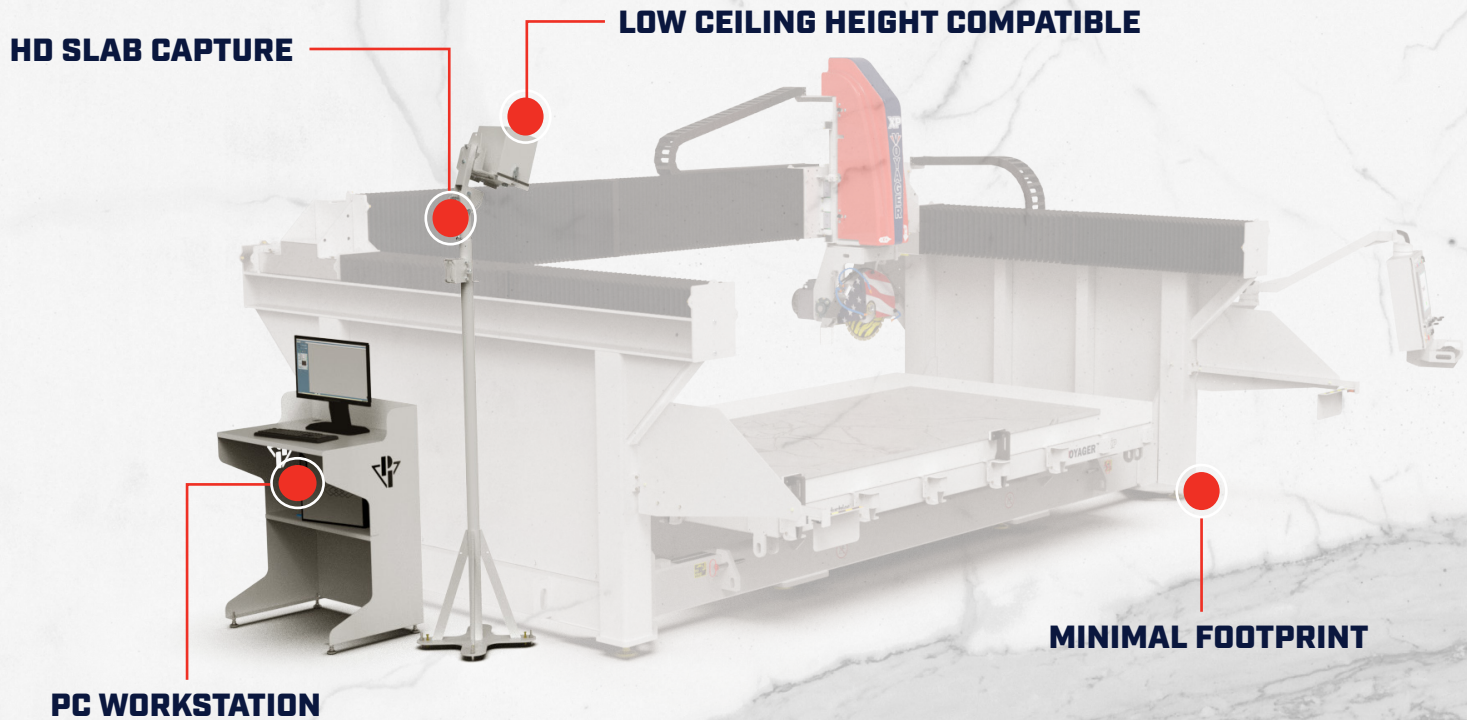

#### KEY SPECS

- Camera: HD Camera
- Max Slab Size: 144" x 84"
- Controller: PC Computer
- Height: 11'3.75"



**SCAN TO LEARN MORE  
ABOUT THIS MACHINE**

# alphacam

**PARK EZ**  
BUTTONS



Park Industries® makes CNC programming FAST and SIMPLE. Our machines pair Alphacam's world-class CAD software with our Park EZ™ Buttons to make tedious tasks a breeze.

## EZ BUTTONS KEY FEATURES

- Triple your programming capacity
- Less rework with reduced errors
- Quickly onboard new programmers
- Save 60% or more of programming time and clicks compared to other softwares
- Over 40 built-in Park EZ Buttons like Auto Toolpath and Ultracompact Automation

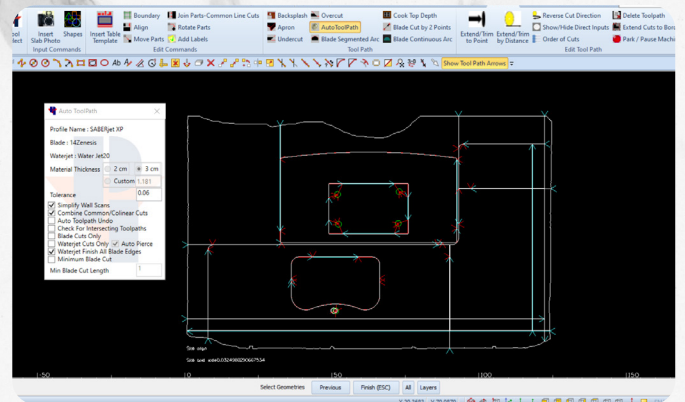

SlabSmith™ is a highly trusted and easy to use software that powers Park Industries photo stations from slab capture through slab properties to digital layout and slab inventory.

## SLABSMITH KEY FEATURES

- Digital slab creation
- Slab layout / veinmatching environment
- Stores all properties (size, defects, etc.) of all slabs / remnants
- Eliminate manual yard searches with live digital slab inventory





Capture everything with tMatch and Slab Inventory software, built exclusively for the SlabVision™ Scanner. These powerful tools redefine veinmatching & slab management, putting precision and efficiency at your fingertips.

### TMATCH KEY FEATURES:

- Powerful slab layout / veinmatching environment
- Exportable 3D Interactive layouts for customer approval
- Define remnants to be returned to inventory
- Creation of DXF cut files for CNC sawing

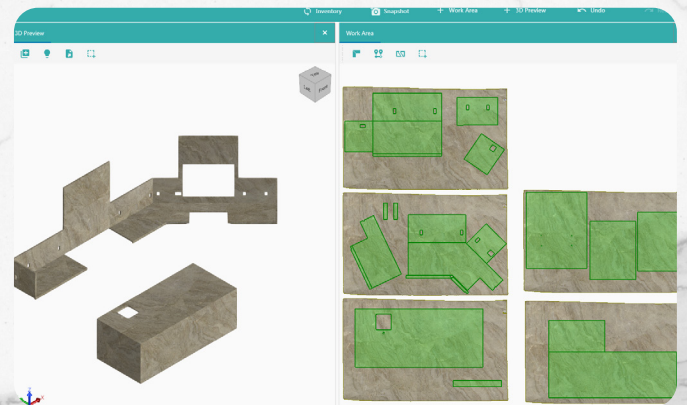

### SLAB INVENTORY KEY FEATURES:

- Exact area and unit counts of your slabs / remnants
- Stores all properties (size, defects, etc) of all slabs / remnants
- Eliminate manual yard searches with live digital slab inventory
- Real-time insights into your material usage and inventory





# TESTIMONIALS



"Park is the top machine partner in the industry. They stand behind their name, are family-owned, and they have a deep commitment to quality, USA Made machines all the way around. We have total Peace of Mind with Park behind us."

**LAURA GRANDLIENARD // ROCKIN'TERIORS**

*VOTED 2024 FABRICATOR OF THE YEAR*



"Park's service is impeccable. Simply unmatched in our industry. Park Industries® is not just an equipment manufacturer, they are a solution provider and a true business partner of ours."

**JOE DUSZKA // CAROLINA CUSTOM SURFACES**

*VOTED 2021 FABRICATOR OF THE YEAR*



"Our Park machines have more than tripled our production, reduced our labor, and eliminated overtime in our shop. I am so happy with them that I joke I get the urge to kiss my machines from Park Industries. They've changed our lives."

**HECTOR & YURI FRANCO // UNIQUE COUNTERTOPS**



**SCAN HERE TO CONTACT US**



A photograph of a modern, single-story industrial building with large glass windows and doors. The building has the "Park Industries" logo and name on its facade. An American flag flies on a tall pole to the right of the building. The foreground shows a paved area and some landscaping. The entire image has a dark blue overlay.

 **Park Industries**

 **PRECISION**  
 **PERFORMANCE**  
**PEACE OF MIND<sup>®</sup>**

**800.328.2309 ▼ [PARKINDUSTRIES.COM](http://PARKINDUSTRIES.COM) ▼ 6301 SAUKVIEW DRIVE, ST. CLOUD, MN 56303**

V1 9.15.25